

After Power ON, the Status LED on a Clevertest Plus enabled fitting will display a rapid Green or Red flashing for a period up to 2 minutes.

**Zoneworks, HIVE (HV/HVG) and DATA Monitored Options**

Fittings with part numbers -ZW, -HV, -HVG, -DATA are fitted with Zoneworks communications modules (nodes). These fittings are monitored using either Powerline Carrier Technology that utilize the power cable to provide data communication, RF transceiver modules operating in the ISM band or a dedicated data cable to/from data routers installed on a dedicated data trunk connected to a central Server (can also be connected via Ethernet/Internet/Fibre). Zoneworks software on the server is used to monitor, coordinate testing and collate test data from each fitting. Zoneworks Fittings can be commissioned by a single push of the test switch or by scanning the supplied barcode. The LED Test Switch indicator provides a multifunction indication of the status of the fitting during testing and normal operation:

Option	State	LED Operation
ZW, HV, HVG, DATA	Commissioned	LED on Solid (Green)
ZW, DATA	Un-commissioned	<b>Batt plugged-in:</b> yellow 1s, green 1s
		<b>Batt unplugged:</b> red 1s, off 1s
HV, HVG	Un-commissioned With network connectivity	<b>Batt plugged-in:</b> yellow 1s, green 1s
		<b>Batt unplugged:</b> red 1s, off 1s
HV, HVG	Un-commissioned Without network connectivity	<b>Batt plugged-in:</b> yellow 250mS, green 250mS, yellow 250mS, green 250mS, green 1s
		<b>Batt unplugged:</b> red 250mS, off 250mS, red 250mS, off 250mS, off 1s
ZW, DATA	Emergency Light Test In Progress	LED flashes at yellow 5s , Off 1s
HV, HVG	Emergency Light Test In Progress	LED flashes at yellow 1s , Off 1s

In the case of the DATA version a 2-way “figure 8” cable and terminal block facilitates the connection to the DATA network via a multi-drop bus (daisy chain connection). For further information of installation of a Zoneworks system, please refer to the Zoneworks Users Guide and Commissioning Guide (incl. DATA version)

**DALI 2 EM Option**

Luminaires with part numbers having -D2 are fitted with DALI 2 certified modules (nodes) that facilitate connection and integration to 3rd Party Lighting Control Systems. Before installing the fitting please confirm that the Lighting Control System has the capability to monitor DALI Emergency Luminaires. The fitting will be addressed and configured into the control system by the Lighting Control System Commissioning Technicians and not Clevertronics

State	LED Operation
Commissioned/ Un-commissioned	LED on Solid (Green)
Emergency Light Test in progress	LED flashes at 1s On (Yellow) & 1s Off
“IDENTIFY COMMAND”	Lamp and Status LED Flash for 30 seconds

A 2-way “figure 8” cable and terminal block facilitates the connection to the DALI network OR a 5/6way “structured wiring system” lead and plug facilitating the power and DALI connection. DALI connections are marked as Da Da..



**L10™ Supalite Weatherproof Emergency Luminaire With Remote Lamp Heads**

**Installation & Maintenance Instruction Leaflet**



**Victoria (Head Office & Manufacturing)**  
 Website: [www.clevertronics.com.au](http://www.clevertronics.com.au)  
 Email: [info@clevertronics.com.au](mailto:info@clevertronics.com.au)  
 Phone: +61 3 9559 2700

**New South Wales**  
 Phone: +61 2 8805 6400

**Queensland**  
 Phone: +61 7 3442 9700

**South Australia/Northern Territory**  
 Phone: +61 8 8301 8800

**Western Australia**  
 Phone: +61 8 9207 0000

**New Zealand**  
 Phone: +64 800 548 448

NOTE: Standard product codes with this symbol  are enabled with Clevertest Plus capability. Please refer to the operation guide supplied with the product for details.

**Models: LWFLED-xx-2IPREM-ss-yy**

**Testing:**  
 Manual Test xx = Blank  
 Zoneworks xx = ZW  
 Z/W DATA xx = DATA  
 Zoneworks HIVE xx = HV/HVG  
 DALI Registered. xx = DALI  
 DALI-2 xx = D2

**Options:**  
 Custom Option ss = TRAYTBCG  
 Black yy = BLK

**Spare Parts:**

1530260 Replacement Battery  
 1100550 Replacement Emergency LED Board  
 AUM01370150001 Replacement Emergency Driver

**Important:**

It is illegal for anyone, except for a licensed electrician to install or maintain this product. Before installation, ensure that the electricity supply has been switched off and isolated. Installation must be carried out in accordance with the relevant Australian and International Standards.

## Installation:

The L10 Weatherproof Supalite (LWFLED-IPREM) is Surface Mounted. The Control gear and Lamp Heads are housed in weather proof enclosures. The enclosures are attached to the wall using screws installed through the 4 isolated holes. Please follow the steps below to install the Weather Proof fitting.

### Control Gear

- Remove the Control Gear cover.
- Remove the gear tray.
- Determine power entry.
- Drill power access hole in the box base.
- Position the box base in the mounting position.
- Mark the 4 holes for mounting. Install the base using appropriate fixings (not supplied).
- Connect the 240VAC supply to the terminal block on the Gear Tray.
- Reinstall the gear tray.

### Remote Lamps

- Remove the enclosure cover.
- Determine cable entry point for LED cable from the Control Gear.
- Drill appropriate hole and install an appropriate cable gland.
- Position the box and mark out the mounting holes. Install the box using appropriate fixings.
- Route and connect the LED drive cables from the Control Gear (LED+, LED-) using appropriate weatherproof glands between the Control Gear and the Lamp Heads to maintain the IP65 rating.

Ensure all the holes drilled on the enclosures are appropriately sealed to maintain the IP rating.

If the CTP capabilities are activated, please affix the CTP status Label to a visible surface and Four Segment Marking on the product will include an "F" in third segment block.

## Networking:

When installing the product on a monitored network, (ZONENETWORKS, HIVE, DATA, DALI) simply insert the relevant Smart Node PCA.

## Dimensions:

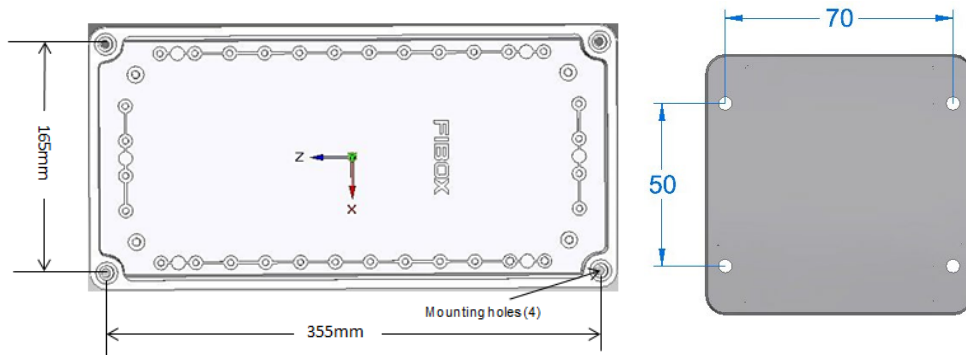

## Testing:

When the Supalite unit is connected to the un-switched active, it must be allowed to charge the battery for at least 24 hours. The emergency lamp only illuminates during a power fail. Conduct the following tests:

- The emergency lamps must illuminate for at least 2 hours after disconnection from the mains. The results of all tests are required to be recorded in a service logbook, which is to be kept on-site at all times. If the unit fails to illuminate for the requisite time, remedial action must be taken to repair the situation and once completed, the unit must pass a subsequent test.
- Press and hold Test Button or switch Off Mains Supply, check that the emergency lamps are On.
- Release the Test Button or Switch On Mains Supply, check that the emergency lamps are Off (Non-maintained operation).

## Trouble Shooting:

Below are a list of common problems and their possible causes.

### Fault: The Green LED Test Switch indicator is not illuminated.

Check: A.C. is connected and is turned on.  
Battery is connected  
Test Switch for damage.

### Fault: Lamp does not illuminate in emergency mode.

Check: A.C. is connected.  
Lamp is correctly inserted.  
Battery is connected

### Fault: Lamp illuminates in emergency mode, but only stays on for a short period.

Check: Battery has been allowed to charge for at least 24 hours.  
Battery for damage.

## Rated Emergency Lumen Output in accordance with AS2293.1, not applicable for –TH (theatre) version (refer to spacing tables for installation positions):

Refer to the Technical Label for classification information.

## Caution:

On many building sites, power circuits may be cut off in an uncontrolled and repetitive basis during construction. As a result, any Exit & Emergency Units, on these circuits, will have their batteries discharged or "cycled". The battery in this fitting has been selected to give excellent long-life performance in a controlled AS2293 testing environment. Excessive battery cycling will reduce through-life performance and may lead to premature battery failure. Battery warranty claims, as a result of such abuse, are specifically EXCLUDED from Clevertronics warranty terms.

## Warranty:

For Product Warranty information and Terms and Conditions of Sales please refer to our website <http://clevertronics.com.au/terms-conditions-sale-australia-nz/>